

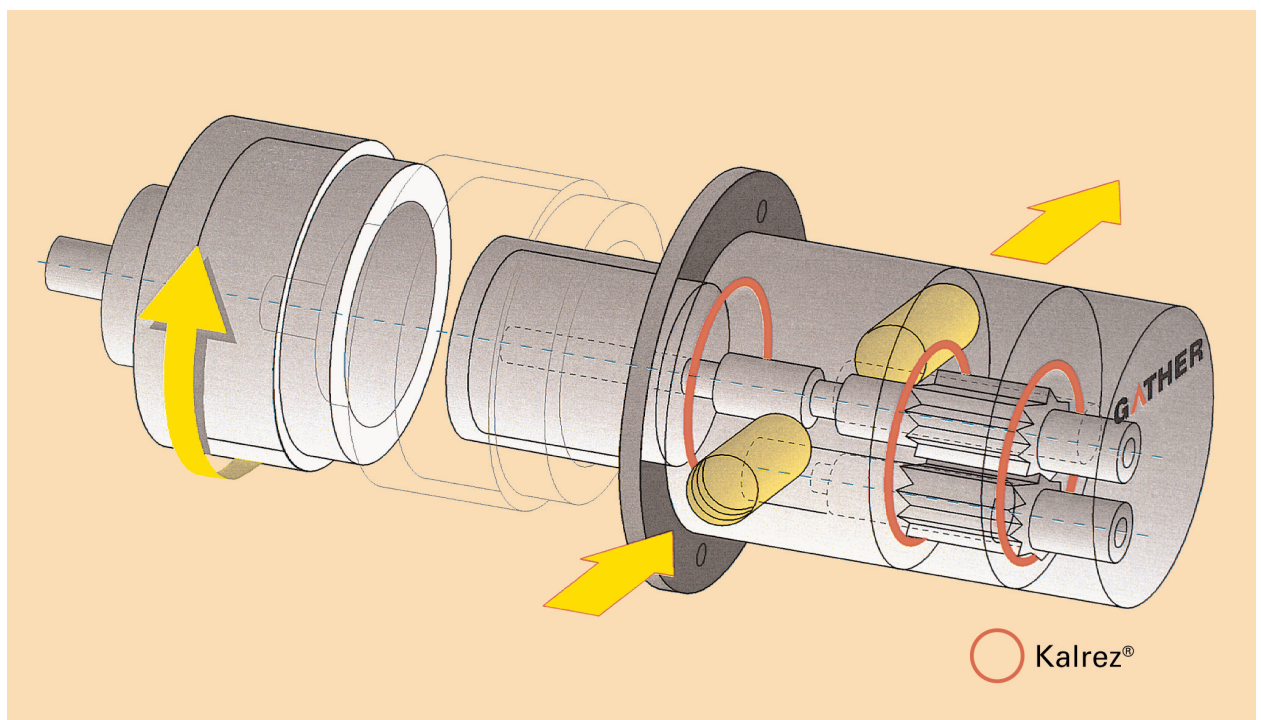

Kalrez[®] perfluoroelastomer
parts

From DuPont Performance Elastomers

Kalrez[®] Solves Gear Pump Seal Deformation Problem, Withstands Operating Extremes



Gear pump by Gather Industrie GmbH is fitted with O-rings of Kalrez[®] perfluoroelastomer from DuPont Performance Elastomers (indicated), to withstand temperature up to 327°C, pressure up to 100 bar and exposure to aggressive media in the chemical process industry, where other sealing materials fail.

By replacing metal/O-rings with Kalrez[®] O-rings from DuPont Performance Elastomers in gear pumps designed to operate in temperature up to 300°C and pressure of 100 bar, Gather Industrie GmbH, Mettmann, Germany, has solved the problem of seal deformation at high temperatures, which was causing leakage at the sealing surfaces and compromising chemical industry safety requirements.

Key markets for pumps, centrifuges and quick-couplings manufactured by Gather are the chemical process and aircraft industries in Austria, Germany and Switzerland. The company's gear pumps are also used in reactors and other difficult operating environments where only Kalrez[®] can meet stringent seal reliability and safety requirements long-term.

Only Kalrez[®] withstands extremes

According to Dipl. Eng. Klaus Lübke, the company's Technical Manager, only Kalrez[®] O-rings were able to withstand long term exposure to aggressive chemicals at such extremes of heat and pressure. In numerous other cases, Kalrez[®] parts fitted up to ten years ago are still working without problem.

Cost savings with Kalrez®

Unlike metal O-rings, the Kalrez® perfluoroelastomer parts also compensates for the uneven internal sealing forces within the asymmetric pump housing, maintaining a leak-free seal, explains Mr. Lübke. He also reports that by switching to Kalrez®, pump assembly and dismantling has been made easier, leading to cost savings through reduced maintenance and production down time. As a result, Kalrez® seals are now fitted as standard equipment in most of Gather's extensive range of gear pumps.

In the 25 years since first commercially introduced, Kalrez® perfluoroelastomer parts have provided superior performance in a wide variety of demanding sealing applications. Kalrez® resists more than 1800 chemicals and is thermally stable up to 327°C.

For further information please contact one of the offices below,
or visit our website at www.dupontelastomers.com

Global Headquarters – Wilmington, DE USA

Tel. +1 800 853 5515
+1 302 792 4000
Fax +1 302 792 4450

South & Central America Headquarters – Brazil

Tel. +55 11 4166 8978
Fax +55 11 4166 8989

Japan Headquarters – Tokyo

Tel. +81 3 5521 2990
Fax +81 3 5521 2991

European Headquarters – Geneva

Tel. +41 22 717 4000
Fax +41 22 717 4001

Asia Pacific Headquarters – Singapore

Tel. +65 6275 9383
Fax +65 6275 9395

The information set forth herein is furnished free of charge and is based on technical data that DuPont Performance Elastomers believes to be reliable. It is intended for use by persons having technical skill, at their own discretion and risk. Handling precaution information is given with the understanding that those using it will satisfy themselves that their particular conditions of use present no health or safety hazards. Since conditions of product use and disposal are outside our control, we make no warranties, express or implied, and assume no liability in connection with any use of this information. As with any material, evaluation of any compound under end-use conditions prior to specification is essential. Nothing herein is to be taken as a license to operate or a recommendation to infringe on patents. While the information presented here is accurate at the time of publication, specifications can change. Check www.dupontelastomers.com for the most up-to-date information.

Caution: Do not use in medical applications involving permanent implantation in the human body. For other medical applications, discuss with your DuPont Performance Elastomers customer service representative and read Medical Caution Statement H-69237.

DuPont™ is a trademark of DuPont and its affiliates.
Kalrez® is a registered trademark of DuPont Performance Elastomers.

Copyright © 2005 DuPont Performance Elastomers.
All rights reserved.

Printed in Switzerland
KZE-D10481-00-B1005

DuPont 
Performance Elastomers